

INSTRUCTIONS–PARTS LIST



ALUMINIUM AND STAINLESS STEEL **VERDERAIR VA 40** Air-Operated Diaphragm Pumps

819.4334

Rev. ZAC
EN

For fluid transfer applications. For professional use only.

8.3 bar Maximum Fluid Working Pressure

8.3 bar Maximum Air Input Pressure



Important Safety Instructions

Read all warnings and instructions in the manual. Save these instructions.

* **NOTE:** Refer to the Pump Listing on page 22 to determine the Model No. of your pump.

Patent No.

CN ZL94102643.4

FR 9408894

JA 3517270

US 5,368,452

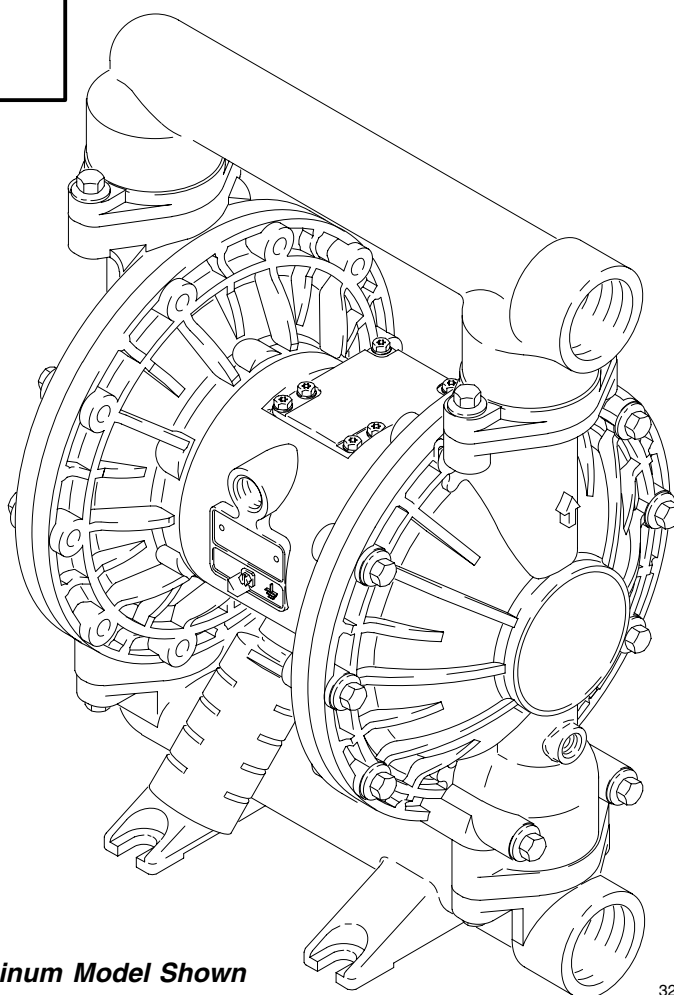

Aluminum Model Shown

3263B



HO03



II 2 GD c IIC T4

Table of Contents

Safety Warnings	2
Symbols	2
Installation	4
Operation	9
Maintenance	10
Troubleshooting	12
Service	
Repairing the Air Valve	14
Ball Check Valve Repair	16
Diaphragm Repair	17
Bearing and Air Gasket Removal	20
Pump Listing	22
Repair Kit Listing	23
Parts	24
Torque Sequence	28
Dimensions	29
Technical Data and Performance Chart	30
Customer Services/Guarantee	32

Symbols

Warning Symbol



This symbol alerts you to the possibility of serious injury or death if you do not follow the instructions.

Caution Symbol



This symbol alerts you to the possibility of damage to or destruction of equipment if you do not follow the instructions.

Warning



INSTRUCTIONS

EQUIPMENT MISUSE HAZARD

Equipment misuse can cause the equipment to rupture or malfunction and result in serious injury.

- This equipment is for professional use only.
- Read all instruction manuals, tags, and labels before operating the equipment.
- Use the equipment only for its intended purpose. If you are not sure, call VERDER After Sales Service.
- Do not alter or modify this equipment.
- Check equipment daily. Repair or replace worn or damaged parts immediately.
- Do not exceed the maximum working pressure of the lowest rated component in your system. This equipment has an **8.4 bar maximum working pressure at 8.4 bar maximum incoming air pressure**.
- Use fluids and solvents which are compatible with the equipment wetted parts. Refer to the **Technical Data** section of all equipment manuals. Read the fluid and solvent manufacturer's warnings.
- Do not use 1,1,1-trichloroethane, methylene chloride, other halogenated hydrocarbon solvents or fluids containing such solvents in pressurized aluminum equipment. Such use could result in a chemical reaction, with the possibility of explosion.
- Do not use hoses to pull equipment.
- Route hoses away from traffic areas, sharp edges, moving parts, and hot surfaces. Do not expose VERDER hoses to temperatures above 82°C or below -40°C.
- Do not lift pressurized equipment.
- Comply with all applicable local, state, and national fire, electrical, and safety regulations.

Warning



TOXIC FLUID HAZARD

Hazardous fluid or toxic fumes can cause serious injury or death if splashed in the eyes or on the skin, inhaled, or swallowed.



- Know the specific hazards of the fluid you are using.
- Store hazardous fluid in an approved container. Dispose of hazardous fluid according to all local, state, and national guidelines.
- Always wear protective eyewear, gloves, clothing, and respirator as recommended by the fluid and solvent manufacturer.
- Pipe and dispose of the exhaust air safely, away from people, animals, and food handling areas. If the diaphragm fails, the fluid is exhausted along with the air. See **Air Exhaust Ventilation** on page 8.



FIRE AND EXPLOSION HAZARD

Improper grounding, poor ventilation, open flames or sparks can cause a hazardous condition and result in a fire or explosion and serious injury.



- Ground the equipment. Refer to **Grounding** on page 4.
- If there is any static sparking or you feel an electric shock while using this equipment, **stop pumping immediately**. Do not use the equipment until you identify and correct the problem.
- Provide fresh air ventilation to avoid the buildup of flammable fumes from solvents or the fluid being sprayed.
- Pipe and dispose of the exhaust air safely, away from all sources of ignition. If the diaphragm fails, the fluid is exhausted along with the air. See **Air Exhaust Ventilation** on page 8.
- Keep the work area free of debris, including solvent, rags, and gasoline.
- Electrically disconnect all equipment in the work area.
- Extinguish all open flames or pilot lights in the work area.
- Do not smoke in the work area.
- Do not turn on or off any light switch in the work area while operating or if fumes are present.
- Do not operate a gasoline engine in the work area.

Installation

General Information

1. The Typical Installation shown in Fig. 2 is only a guide for selecting and installing system components. Contact your VERDER Customer Service for assistance in planning a system to suit your needs.
2. Always use Genuine VERDER Parts and Accessories. Refer to Product Data Sheet 819.4335.
3. Reference numbers and letters in parentheses refer to the callouts in the figures and the parts lists on pages 24–25.
4. Lift the pump by grasping the outlet manifold (1) securely. See Fig. 3 on page 7.

Warning



TOXIC FLUID HAZARD

Hazardous fluid or toxic fumes can cause serious injury or death if splashed in the eyes or on the skin, inhaled, or swallowed.

1. Read **TOXIC FLUID HAZARD** on page 3.
2. Use fluids and solvents which are compatible with the equipment wetted parts. Refer to the **Technical Data** section of all equipment manuals. Read the fluid and solvent manufacturer's warnings.

Tightening Screws Before First Use

Before using the pump for the first time, check and retorque all external fasteners. See **Torque Sequence**, page 28. After the first day of operation, retorque the fasteners. Although pump use varies, a general guideline is to retorque fasteners every two months.

Grounding

Warning



FIRE AND EXPLOSION HAZARD

This pump must be grounded. Before operating the pump, ground the system as explained below. Also, read the section **FIRE AND EXPLOSION HAZARD**, on page 3.



To reduce the risk of static sparking, ground the pump and all other equipment used or located in the pumping area. Check your local electrical code for detailed grounding instructions for your area and type of equipment.

Ground all of this equipment:

- *Pump:* Connect a ground wire and clamp as shown in Fig. 1. Loosen the grounding screw (W). Insert one end of a 1.5 mm² minimum ground wire (Y) behind the grounding screw and tighten the screw securely. Connect the clamp end of the ground wire to a true earth ground. Order Part No. 819.0157 Ground Wire and Clamp.

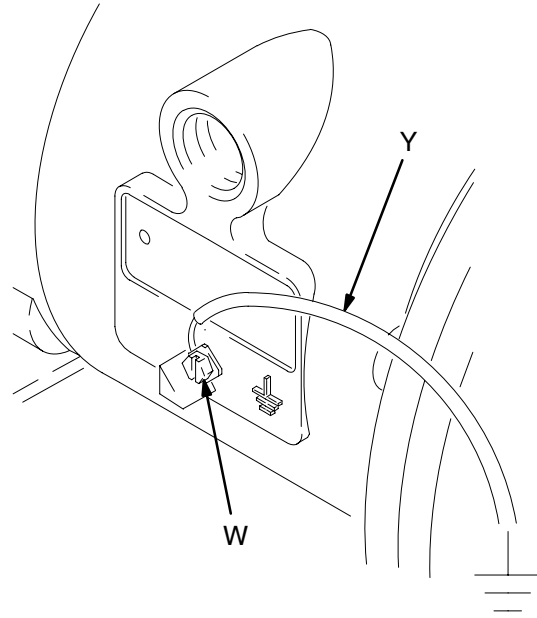

Fig. 1

02646B

- *Air and fluid hoses:* Use only grounded hoses with a maximum of 150 m combined hose length to ensure grounding continuity.
- *Air compressor:* Follow the manufacturer's recommendations.
- *All solvent pails used when flushing,* according to local code. Use only metal pails, which are conductive. Do not place the pail on a non-conductive surface, such as paper or cardboard, which interrupts the grounding continuity.
- *Fluid supply container:* Follow the local code.

Installation

Mountings

Caution

The pump exhaust air may contain contaminants. Ventilate to a remote area if the contaminants could affect your fluid supply. See **Air Exhaust Ventilation** on page 8.

1. Be sure the mounting surface can support the weight of the pump, hoses, and accessories, as well as the stress caused during operation.
2. For all mountings, be sure the pump is bolted directly to the mounting surface.
3. For ease of operation and service, mount the pump so the air valve cover (2), air inlet, and fluid inlet and outlet ports are easily accessible.
4. Rubber Foot Mounting Kit 819.4333 is available to reduce noise and vibration during operation.

Air Line

Warning

A bleed-type master air valve (B) is required in your system to relieve air trapped between this valve and the pump. Trapped air can cause the pump to cycle unexpectedly, which could result in serious injury, including splashing in the eyes or on the skin, injury from moving parts, or contamination from hazardous fluids. See Fig. 2.

1. Install the air line accessories as shown in Fig. 2. Mount these accessories on the wall or on a bracket. Be sure the air line supplying the accessories is grounded.
 - a. Install an air regulator (C) and gauge to control the fluid pressure. The fluid outlet pressure will be the same as the setting of the air regulator.
 - b. Locate one bleed-type master air valve (B) close to the pump and use it to relieve trapped air. See the **Warning** above. Locate the other master air valve (E) upstream from all air line accessories and use it to isolate them during cleaning and repair.
 - c. The air line filter (F) removes harmful dirt and moisture from the compressed air supply.

2. Install a grounded, flexible air hose (A) between the accessories and the 1/2 npt(f) pump air inlet (N). See Fig. 3. Use a minimum 13 mm ID air hose. Screw an air line quick disconnect coupler (D) onto the end of the air hose (A), and screw the mating fitting into the pump air inlet snugly. Do not connect the coupler (D) to the fitting until you are ready to operate the pump.

Fluid Suction Line

1. **Use grounded fluid hoses (G).** The pump fluid inlet (R) is 1–1/2 in. bspt. On pumps 810.0195, 810.0196, 810.0197, and 810.0198, the pump fluid inlet is 1–1/2 in. npt. Screw the fluid fitting into the pump inlet securely.
2. If the fluid inlet pressure to the pump is more than 25% of the outlet working pressure, the ball check valves will not close fast enough, resulting in inefficient pump operation.
3. At inlet fluid pressures greater than 1.05 bar, diaphragm life will be shortened.
4. See the **Technical Data** on page 30 for maximum suction lift (wet and dry).

Fluid Outlet Line

Warning

A fluid drain valve (J) is required to relieve pressure in the hose if it is plugged. The drain valve reduces the risk of serious injury, including splashing in the eyes or on the skin, or contamination from hazardous fluids when relieving pressure. Install the valve close to the pump fluid outlet. See Fig. 2.

1. **Use grounded fluid hoses (L).** The pump fluid outlet (S) is 1–1/2 in. bspt. On pumps 810.0195, 810.0196, 810.0197, and 810.0198, the pump fluid outlet is 1–1/2 in. npt. Screw the fluid fitting into the pump outlet securely.
2. Install a fluid drain valve (J) near the fluid outlet. See the **Warning** above.
3. Install a shutoff valve (K) in the fluid outlet line.

Installation

FLOOR MOUNT TYPICAL INSTALLATION

KEY

- A Air Supply Hose
- B Bleed-Type Master Air Valve (required for pump)
- C Air Regulator
- D Air Line Quick Disconnect
- E Master Air Valve (for accessories)
- F Air Line Filter
- G Fluid Suction Hose
- H Fluid Supply
- J Fluid Drain Valve (required)
- K Fluid Shutoff Valve
- L Fluid Hose
- R* 1-1/2 in. bspt Fluid Inlet Port
- S* 1-1/2 in. bspt Fluid Outlet Port
- Y Ground Wire (required; see page 4 for installation instructions)

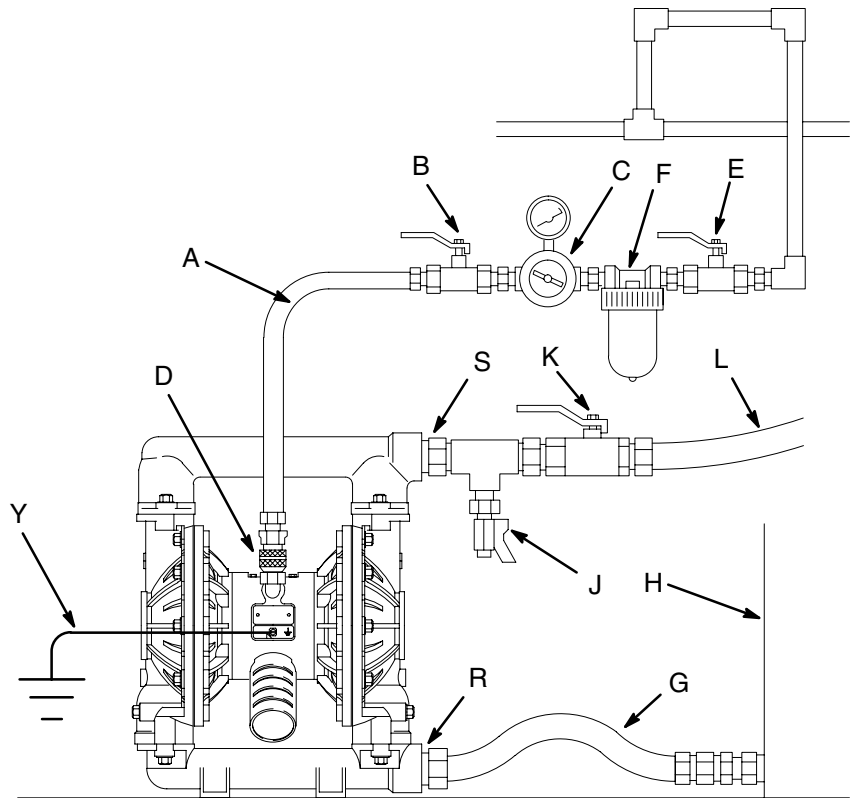

Fig. 2

03265B

* On pumps 810.0195, 810.0196, 810.0197, and 810.0198, inlet and outlet ports are 1-1/2 in. npt threads.

Installation

Changing the Orientation of the Fluid Inlet and Outlet Ports

The pump is shipped with the fluid inlet (R) and outlet (S) ports facing the same direction. See Fig. 3. To change the orientation of the inlet and/or outlet port:

1. Remove the screws (106) holding the inlet (102) and/or outlet (103) manifold to the covers (101).
2. Reverse the manifold and reattach. Install the screws and torque to 14–17 N•m. See **Torque Sequence**, page 28.

KEY

N	1/2 npt(f) Air Inlet Port	101	Covers
P	Muffler; Air Exhaust Port is 3/4 npt(f)	102	Fluid Inlet Manifold
R*	1–1/2 in. bspt Fluid Inlet Port	103	Fluid Outlet Manifold
S*	1–1/2 in. bspt Fluid Outlet Port	106	Manifold and Cover Screws
		112	Bottom Cover Screws

- 1 Torque to 14–17 N•m. See **Torque Sequence**, page 28.
- 2 Torque to 22–25 N•m. See **Torque Sequence**, page 28.

Aluminum Model Shown

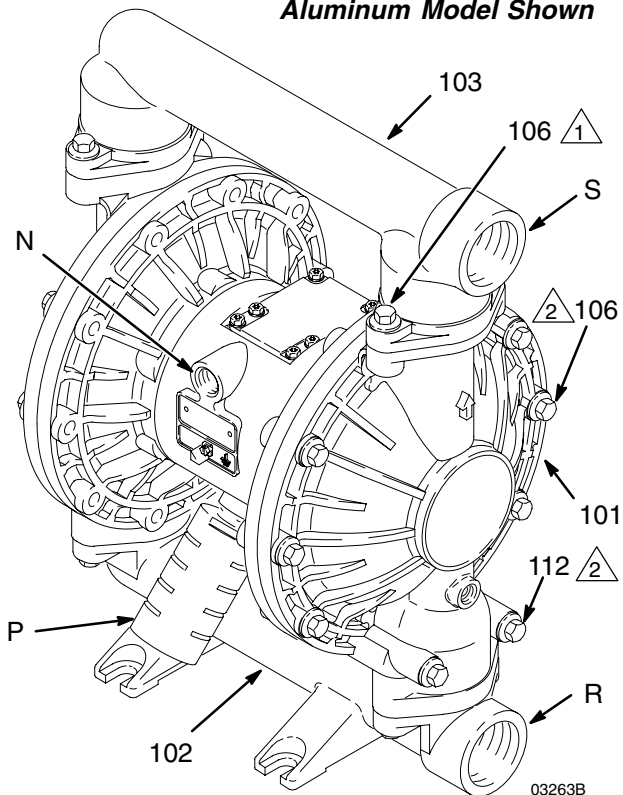

Fig. 3

Fluid Pressure Relief Valve

⚠ Caution

Some systems may require installation of a pressure relief valve at the pump outlet to prevent overpressurization and rupture of the pump or hose. See Fig. 4.

Thermal expansion of fluid in the outlet line can cause overpressurization. This can occur when using long fluid lines exposed to sunlight or ambient heat, or when pumping from a cool to a warm area (for example, from an underground tank).

Overpressurization can also occur if the pump is being used to feed fluid to a piston pump, and the intake valve of the piston pump does not close, causing fluid to back up in the outlet line.

KEY

R*	1–1/2 in. bspt Fluid Inlet Port
S*	1–1/2 in. bspt Fluid Outlet Port
V	Pressure Relief Valve (Order Part No. 819.0159)

- 1 Install valve between fluid inlet and outlet ports.
- 2 Connect fluid inlet line here.
- 3 Connect fluid outlet line here.

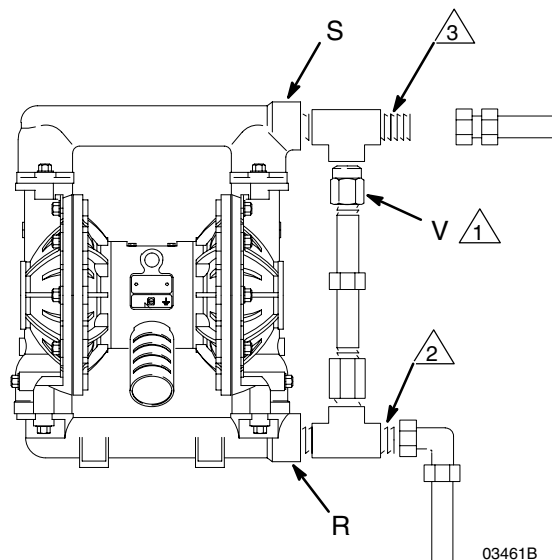

Fig. 4

* On pumps 810.0195, 810.0196, 810.0197, and 810.0198, inlet and outlet ports are 1–1/2 in. npt threads.

Installation

Air Exhaust Ventilation

Warning



FIRE AND EXPLOSION HAZARD

Be sure to read and follow the warnings and precautions regarding **TOXIC FLUID HAZARD**, and **FIRE OR EXPLOSION HAZARD** on page 3, before operating this pump.

Be sure the system is properly ventilated for your type of installation. You must vent the exhaust to a safe place, away from people, animals, food handling areas, and all sources of ignition when pumping flammable or hazardous fluids.

Diaphragm failure will cause the fluid being pumped to exhaust with the air. Place an appropriate container at the end of the air exhaust line to catch the fluid. See Fig. 5.

The air exhaust port is 3/4 npt(f). Do not restrict the air exhaust port. Excessive exhaust restriction can cause erratic pump operation.

If the muffler (P) is installed directly to the air exhaust port, apply PTFE thread tape or anti-seize thread lubricant to the muffler threads before assembly.

To provide a remote exhaust:

1. Remove the muffler (P) from the pump air exhaust port.
2. Install a grounded air exhaust hose (T) and connect the muffler (P) to the other end of the hose. The minimum size for the air exhaust hose is 19 mm ID. If a hose longer than 4.57 m is required, use a larger diameter hose. Avoid sharp bends or kinks in the hose. See Fig. 5.
3. Place a container (U) at the end of the air exhaust line to catch fluid in case a diaphragm ruptures.

VENTING EXHAUST AIR

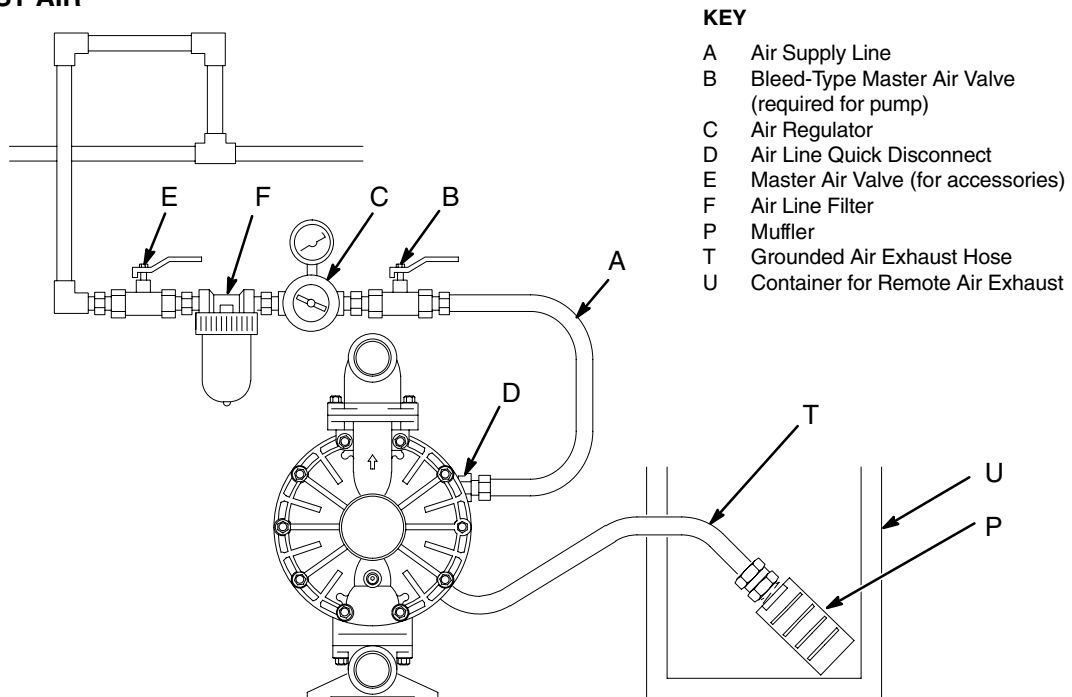

KEY

- A Air Supply Line
- B Bleed-Type Master Air Valve (required for pump)
- C Air Regulator
- D Air Line Quick Disconnect
- E Master Air Valve (for accessories)
- F Air Line Filter
- P Muffler
- T Grounded Air Exhaust Hose
- U Container for Remote Air Exhaust

Fig. 5

03267A

Operation

Pressure Relief Procedure

Warning

PRESSURIZED EQUIPMENT HAZARD

The equipment stays pressurized until pressure is manually relieved. To reduce the risk of serious injury from pressurized fluid, accidental spray from the gun or splashing fluid, follow this procedure whenever you:

- Are instructed to relieve pressure,
- Stop pumping,
- Check, clean or service any system equipment,
- Install or clean fluid nozzles.

1. Shut off the air to the pump.
2. Open the dispensing valve, if used.
3. Open the fluid drain valve to relieve all fluid pressure, having a container ready to catch the drainage.

Flush the Pump Before First Use

The pump was tested with lightweight oil, which is left in the fluid passages to protect parts. To avoid contaminating your fluid with oil, flush the pump with a compatible solvent before using the equipment. Follow the steps under **Starting and Adjusting the Pump**.

Starting and Adjusting the Pump

Warning



TOXIC FLUID HAZARD

To reduce the risk of serious injury, splashing in the eyes or on the skin, and toxic fluid spills, **never** move or lift a pump under pressure. If dropped, the fluid section may

rupture. Always follow the **Pressure Relief Procedure** above before lifting the pump.

1. Be sure the pump is properly grounded. Refer to **Grounding** on page 4.
2. Check all fittings to be sure they are tight. Be sure to use a compatible liquid thread sealant on all male threads. Tighten the fluid inlet and outlet fittings securely.
3. Place the suction tube (if used) in the fluid to be pumped.

NOTE: If the fluid inlet pressure to the pump is more than 25% of the outlet working pressure, the ball check valves will not close fast enough, resulting in inefficient pump operation.

4. Place the end of the fluid hose (L) into an appropriate container.

5. Close the fluid drain valve (J). See Fig. 2.
6. Close the pump air regulator (C). Open all bleed-type master air valves (B, E).
7. If the fluid hose has a dispensing device, hold it open while continuing with the following step.
8. Slowly open the air regulator (C) until the pump starts to cycle. Allow the pump to cycle slowly until all air is pushed out of the lines and the pump is primed.

If you are flushing, run the pump long enough to thoroughly clean the pump and hoses. Close the air regulator. Remove the suction tube from the solvent and place it in the fluid to be pumped.

Pump Shutdown

Warning

To reduce the risk of serious injury whenever you are instructed to relieve pressure, always follow the **Pressure Relief Procedure** at left.

At the end of the work shift, relieve the pressure.

Maintenance

Lubrication

The air valve is designed to operate unlubricated, however if lubrication is desired, every 500 hours of operation (or monthly) remove the hose from the pump air inlet and add two drops of machine oil to the air inlet.

Caution

Do not over-lubricate the pump. Oil is exhausted through the muffler, which could contaminate your fluid supply or other equipment. Excessive lubrication can also cause the pump to malfunction.

Flushing and Storage

Warning

To reduce the risk of serious injury whenever you are instructed to relieve pressure, always follow the **Pressure Relief Procedure** on page 9.

Flush the pump often enough to prevent the fluid you are pumping from drying or freezing in the pump and damaging it. Use a compatible solvent.

Always flush the pump and relieve the pressure before storing it for any length of time.

Tightening Threaded Connections

Before each use, check all hoses for wear or damage, and replace as necessary. Check to be sure all threaded connections are tight and leak-free. Check fasteners. Tighten or retorque as necessary. Although pump use varies, a general guideline is to retorque fasteners every two months. See **Torque Sequence**, page 28.

Preventive Maintenance Schedule

Establish a preventive maintenance schedule, based on the pump's service history. This is especially important for prevention of spills or leakage due to diaphragm failure.

Notes

Troubleshooting

Warning

To reduce the risk of serious injury whenever you are instructed to relieve pressure, always follow the **Pressure Relief Procedure** on page 9.

1. Relieve the pressure before checking or servicing the equipment.
2. Check all possible problems and causes before disassembling the pump.

PROBLEM	CAUSE	SOLUTION
Pump cycles at stall or fails to hold pressure at stall.	Worn check valve balls (301), seats (201) or o-rings (202).	Replace. See page 16.
Pump will not cycle, or cycles once and stops.	Air valve is stuck or dirty.	Disassemble and clean air valve. See pages 14–15. Use filtered air.
	Check valve ball (301) severely worn and wedged in seat (201) or manifold (102 or 103).	Replace ball and seat. See page 16.
	Check valve ball (301) is wedged into seat (201), due to overpressurization.	Install Pressure Relief Valve (see page 7).
	Dispensing valve clogged.	Relieve pressure and clear valve.
Pump operates erratically.	Clogged suction line.	Inspect; clear.
	Sticky or leaking balls (301).	Clean or replace. See page 16.
	Diaphragm ruptured.	Replace. See pages 17–19.
	Restricted exhaust.	Remove restriction.
Air bubbles in fluid.	Suction line is loose.	Tighten.
	Diaphragm ruptured.	Replace. See pages 17–19.
	Loose inlet manifold (102), damaged seal between manifold and seat (201), damaged o-rings (202).	Tighten manifold bolts (106) or replace seats (201) or o-rings (202). See page 16.
	Loose diaphragm shaft bolt (107).	Tighten or replace. See pages 17–19.
	Damaged o-ring (108).	Replace. See pages 17–19.

Troubleshooting

PROBLEM	CAUSE	SOLUTION
Fluid in exhaust air.	Diaphragm ruptured.	Replace. See pages 17–19.
	Loose diaphragm shaft bolt (107).	Tighten or replace. See pages 17–19.
	Damaged o-ring (108).	Replace. See pages 17–19.
Pump exhausts excessive air at stall.	Worn air valve block (7†■), o-ring (6†■), plate (8■), pilot block (18), u-cups (10†■), or pilot pin o-rings (17†■).	Repair or replace. See pages 14–15.
	Worn shaft seals (402).	Replace. See pages 17–19.
Pump leaks air externally.	Air valve cover (2) or air valve cover screws (3) are loose.	Tighten screws. See page 15.
	Air valve gasket (4†■) or air cover gasket (22) is damaged.	Inspect; replace. See pages 14–15, 20–21.
	Air cover screws (25) are loose.	Tighten screws. See pages 20–21.
Pump leaks fluid externally from ball check valves.	Loose manifolds (102, 103), damaged seal between manifold and seat (201), damaged o-rings (202).	Tighten manifold bolts (106) or replace seats (201) or o-rings (202). See page 16.

Service

Repairing the Air Valve

Tools Required

- Torque wrench
- Torx (T20) screwdriver or 7 mm socket wrench
- Needle-nose pliers
- O-ring pick
- Lithium base grease

NOTE: Air Valve Repair Kits 819.4274 (aluminum center housing models) and 819.0249 (sst center housing models) are available. Refer to page 23. Parts included in the kit are marked with a symbol, for example (4†■). Use all the parts in the kit for the best results.

Disassembly

Warning

To reduce the risk of serious injury whenever you are instructed to relieve pressure, always follow the **Pressure Relief Procedure** on page 9.

1. Relieve the pressure.
2. With a Torx (T20) screwdriver or 7 mm socket wrench, remove the six screws (3), air valve cover (2), and gasket (4). See Fig. 6.
3. Move the valve carriage (5) to the center position and pull it out of the cavity. Remove the valve block (7) and o-ring (6) from the carriage. Using a needle-nose pliers, pull the pilot block (18) straight up and out of the cavity. See Fig. 7.
4. Pull the two actuator pistons (11) out of the bearings (12). Remove the u-cup packings (10†■) from the pistons. Pull the pilot pins (16) out of the bearings (15). Remove the o-rings (17†■) from the pilot pins. See Fig. 8.
5. Inspect the valve plate (8■) in place. If damaged, use a Torx (T20) screwdriver or 7 mm socket wrench to remove the three screws (3). Remove the valve plate (8■) and, on aluminum center housing models, remove the seal (9†). See Fig. 9.
6. Inspect the bearings (12, 15) in place. See Fig. 8. The bearings are tapered and, if damaged, must be removed from the outside. This requires disassembly of the fluid section. See page 20.
7. Clean all parts and inspect for wear or damage. Replace as needed. Reassemble as explained on page 15.

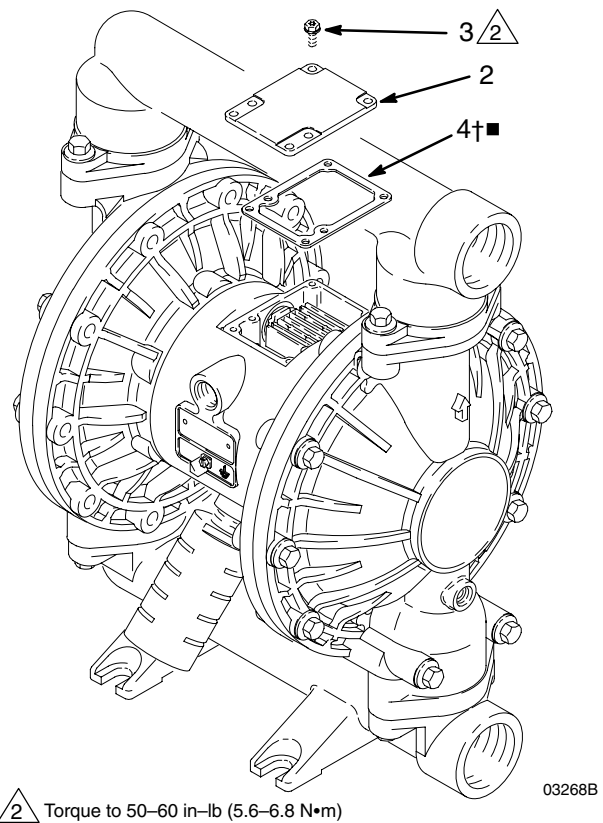

Fig. 6

- 1 See Detail at right.
- 2 Grease.
- 3 Grease lower face.

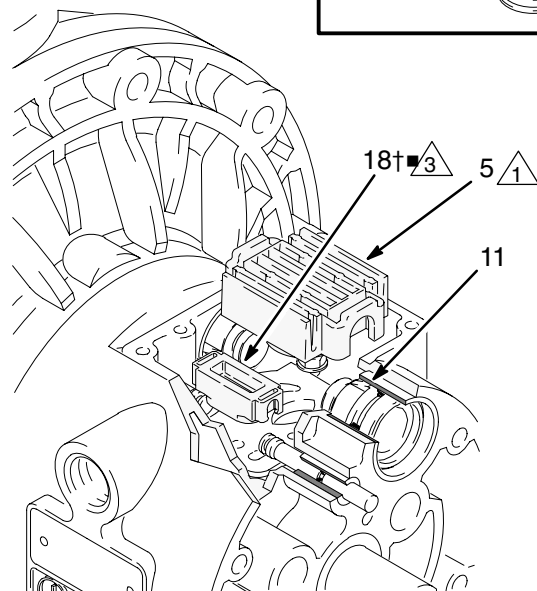
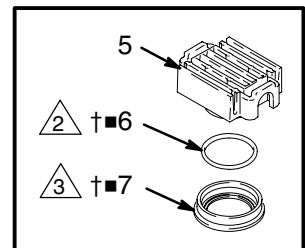

Fig. 7

Service

- 1 Insert narrow end first.
- 2 Grease.
- 3 Install with lips facing narrow end of piston (11).
- 4 Insert wide end first.

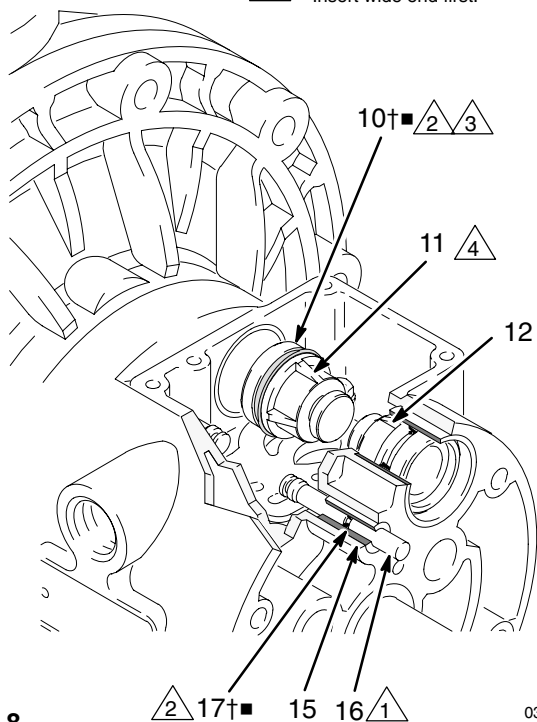

Fig. 8

03270B

- 1 Rounded side must face down (aluminum center housing models only).
- 2 Tighten screws until they bottom out on the housing.

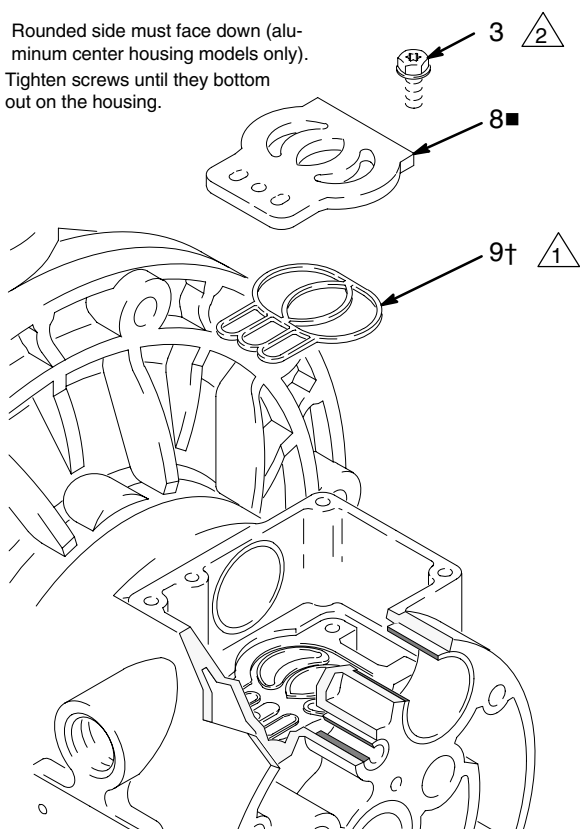

Fig. 9

03271

Reassembly

1. *If you removed the bearings (12, 15),* install new ones as explained on page 20. Reassemble the fluid section.
2. On aluminum center housing models, install the valve plate seal (9†) into the groove at the bottom of the valve cavity. The rounded side of the seal **must face down** into the groove. See Fig. 9.
3. Install the valve plate (8■) in the cavity. On aluminum center housing models, the plate is reversible, so either side can face up. Install the three screws (3), using a Torx (T20) screwdriver or 7 mm socket wrench. Tighten until the screws bottom out on the housing. See Fig. 9.
4. Install an o-ring (17†■) on each pilot pin (16). Grease the pins and o-rings. Insert the pins into the bearings (15), **narrow** end first. See Fig. 8.
5. Install a u-cup packing (10†■) on each actuator piston (11), so the lips of the packings face the **narrow** end of the pistons. See Fig. 8.
6. Lubricate the u-cup packings (10†■) and actuator pistons (11). Insert the actuator pistons in the bearings (12), **wide** end first. Leave the narrow end of the pistons exposed. See Fig. 8.
7. Grease the lower face of the pilot block (18†■) and install so its tabs snap into the grooves on the ends of the pilot pins (16). See Fig. 7.
8. Grease the o-ring (6†■) and install it in the valve block (7†■). Push the block onto the valve carriage (5). Grease the lower face of the valve block. See Fig. 7.
9. Install the valve carriage (5) so its tabs slip into the grooves on the narrow end of the actuator pistons (11). See Fig. 7.
10. Align the valve gasket (4†■) and cover (2) with the six holes in the center housing (1). Secure with six screws (3), using a Torx (T20) screwdriver or 7 mm socket wrench. Torque to 50–60 in-lb (5.6–6.8 N•m). See Fig. 6.

Service

Ball Check Valve Repair

Tools Required

- Torque wrench
- 13 mm socket wrench
- O-ring pick

Disassembly

NOTE: A Fluid Section Repair Kit is available. Refer to page 23 to order the correct kit for your pump. Parts included in the kit are marked with an asterisk, for example (201*). Use all the parts in the kit for the best results.

NOTE: To ensure proper seating of the balls (301), always replace the seats (201) when replacing the balls. Also, on some models, replace the o-rings (202).





Warning

To reduce the risk of serious injury whenever you are instructed to relieve pressure, always follow the **Pressure Relief Procedure** on page 9.

1. Relieve the pressure. Disconnect all hoses.
2. Remove the pump from its mounting.
3. Using a 13 mm socket wrench, remove the four bolts (106) holding the outlet manifold (103) to the fluid covers (101). See Fig. 10.
4. Remove the o-rings (202, *not used on some models*), seats (201), and balls (301) from the manifold.
5. Turn the pump over and remove the inlet manifold (102). Remove the o-rings (202, *not used on some models*), seats (201), and balls (301) from the fluid covers (101).

Reassembly

1. Clean all parts and inspect for wear or damage. Replace parts as needed.
2. Reassemble in the reverse order, following all notes in Fig. 10. Be sure the ball checks are assembled **exactly** as shown. The arrows (A) on the fluid covers (101) **must** point toward the outlet manifold (103).

- 1  Torque to 14–17 N•m. See **Torque Sequence**, page 28.
- 2  Arrow (A) must point toward outlet manifold (103).
- 3  Not used on some models.
- 4  Beveled seating surface must face ball (301).

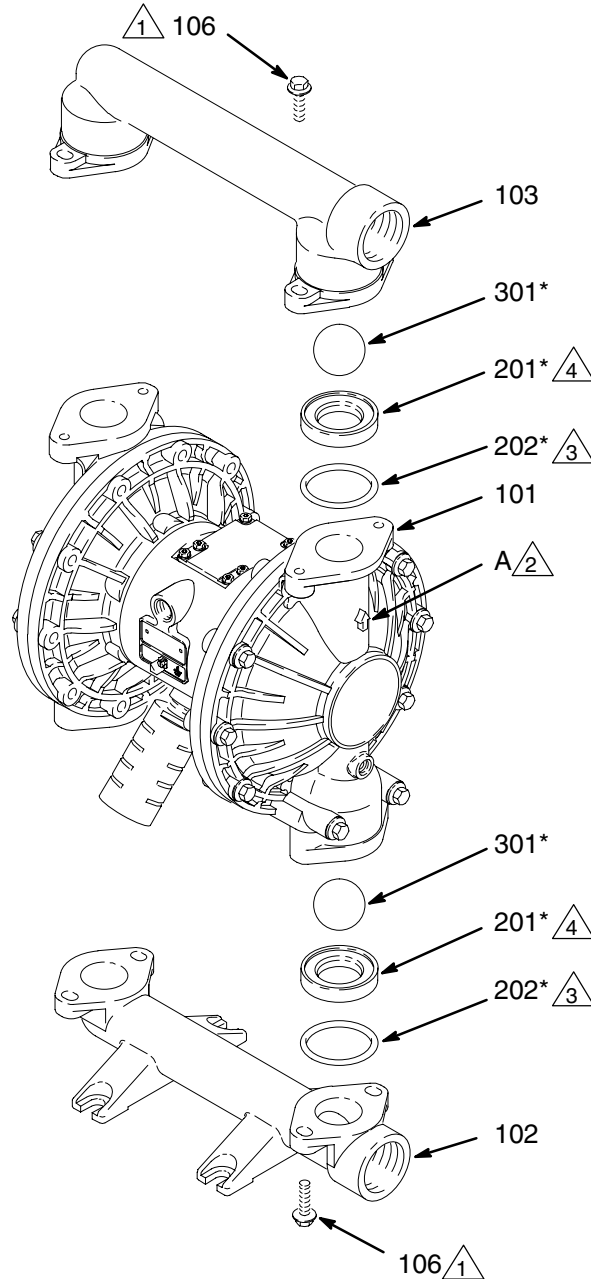

Fig. 10

03272B

Service

Diaphragm Repair

Tools Required

- Torque wrench
- 13 mm open-end wrench
- 15 mm socket wrench (aluminum models) or 1 in. socket wrench (stainless steel models)
- 19 mm socket wrench
- O-ring pick
- Lithium-base grease

Disassembly

NOTE: A Fluid Section Repair Kit is available. Refer to page 23 to order the correct kit for your pump. Parts included in the kit are marked with an asterisk, for example (401*). Use all the parts in the kit for the best results.

⚠ Warning

To reduce the risk of serious injury whenever you are instructed to relieve pressure, always follow the **Pressure Relief Procedure** on page 9.

1. Relieve the pressure.
2. Remove the manifolds and disassemble the ball check valves as explained on page 16.
3. Using a 13 mm socket wrench, remove the screws (106 and 112) holding the fluid covers (101) to the air covers (23). Pull the fluid covers (101) off the pump. See Fig. 11.

- 1 Torque to 22–25 N•m. See **Torque Sequence**, page 28.
- 2 Arrow (A) must point toward air valve (B).

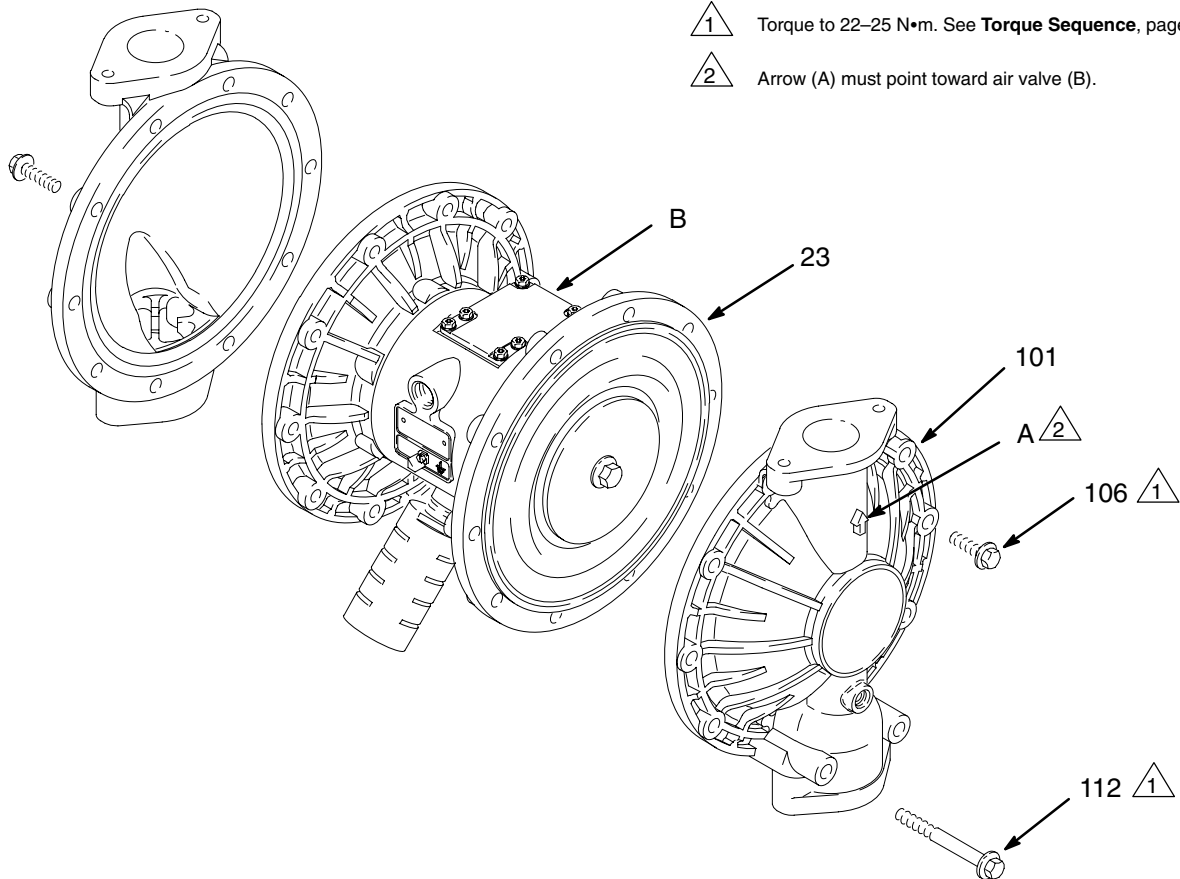

Fig. 11

03273B

Service

4. Loosen but do not remove the diaphragm shaft bolts (107), using a 15 mm socket wrench (1 in. on stainless steel models) on both bolts.
5. Unscrew one bolt from the diaphragm shaft (24) and remove the o-ring (108), fluid side diaphragm plate (105), PTFE diaphragm (403, *used on PTFE models only*), diaphragm (401), and air side diaphragm plate (104). See Fig. 12.
6. Pull the other diaphragm assembly and the diaphragm shaft (24) out of the center housing (1). Hold the shaft flats with a 19 mm open-end wrench, and remove the bolt (107) from the shaft. Disassemble the remaining diaphragm assembly.
7. Inspect the diaphragm shaft (24) for wear or scratches. If it is damaged, inspect the bearings (19) in place. If the bearings are damaged, refer to page 20.
8. Reach into the center housing (1) with an o-ring pick and hook the u-cup packings (402), then pull them out of the housing. This can be done with the bearings (19) in place.
9. Clean all parts and inspect for wear or damage. Replace parts as needed.
- b. Install the fluid side diaphragm plate (105) on the bolt so the rounded side faces in, toward the diaphragm (401).
- c. *On PTFE models only*, install the PTFE diaphragm (403*). Make certain the side marked AIR SIDE faces the center housing (1).
- d. Install the diaphragm (401*) on the bolt. Make certain the side marked AIR SIDE faces the center housing (1).
- e. Install the air side diaphragm plate (104) so the recessed side faces the diaphragm (401).
- f. Apply medium-strength Loctite® or equivalent to the bolt (107) threads. Screw the bolt (107) into the shaft (24) handtight.

Reassembly

1. Install the shaft u-cup packings (402*) so the lips face **out** of the housing (1). Lubricate the packings. See Fig. 12.
2. Install the diaphragm assembly on one end of the shaft (24) as follows:
 - a. Install the o-ring (108*) on the shaft bolt (107).
3. Grease the length and ends of the diaphragm shaft (24), and slide it through the housing (1).
4. Assemble the other diaphragm assembly to the shaft as explained in step 2.
5. Hold one shaft bolt (107) with a wrench and torque the other bolt to 27–34 N•m at 100 rpm maximum.
6. Align the fluid covers (101) and the center housing (1) so the arrows (A) on the covers face the same direction as the air valve (B). Secure the covers with the screws (106 and 112), handtight. Install the longer screws (112) in the bottom holes of the covers. See Fig. 11. Using a 13 mm socket wrench, torque the screws oppositely and evenly to 22–25 N•m. See **Torque Sequence**, page 28.
7. Reassemble the ball check valves and manifolds as explained on page 16.

Service

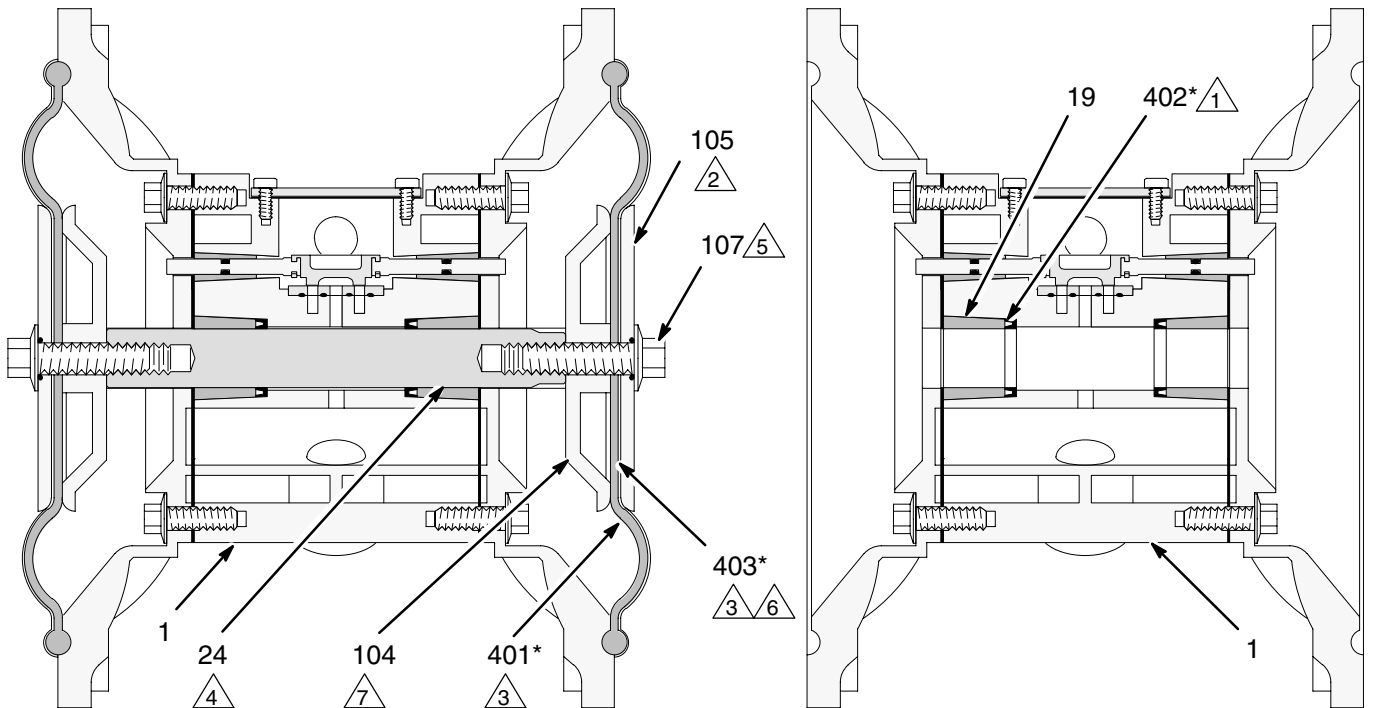

Cutaway View, with Diaphragms in Place

Cutaway View, with Diaphragms Removed

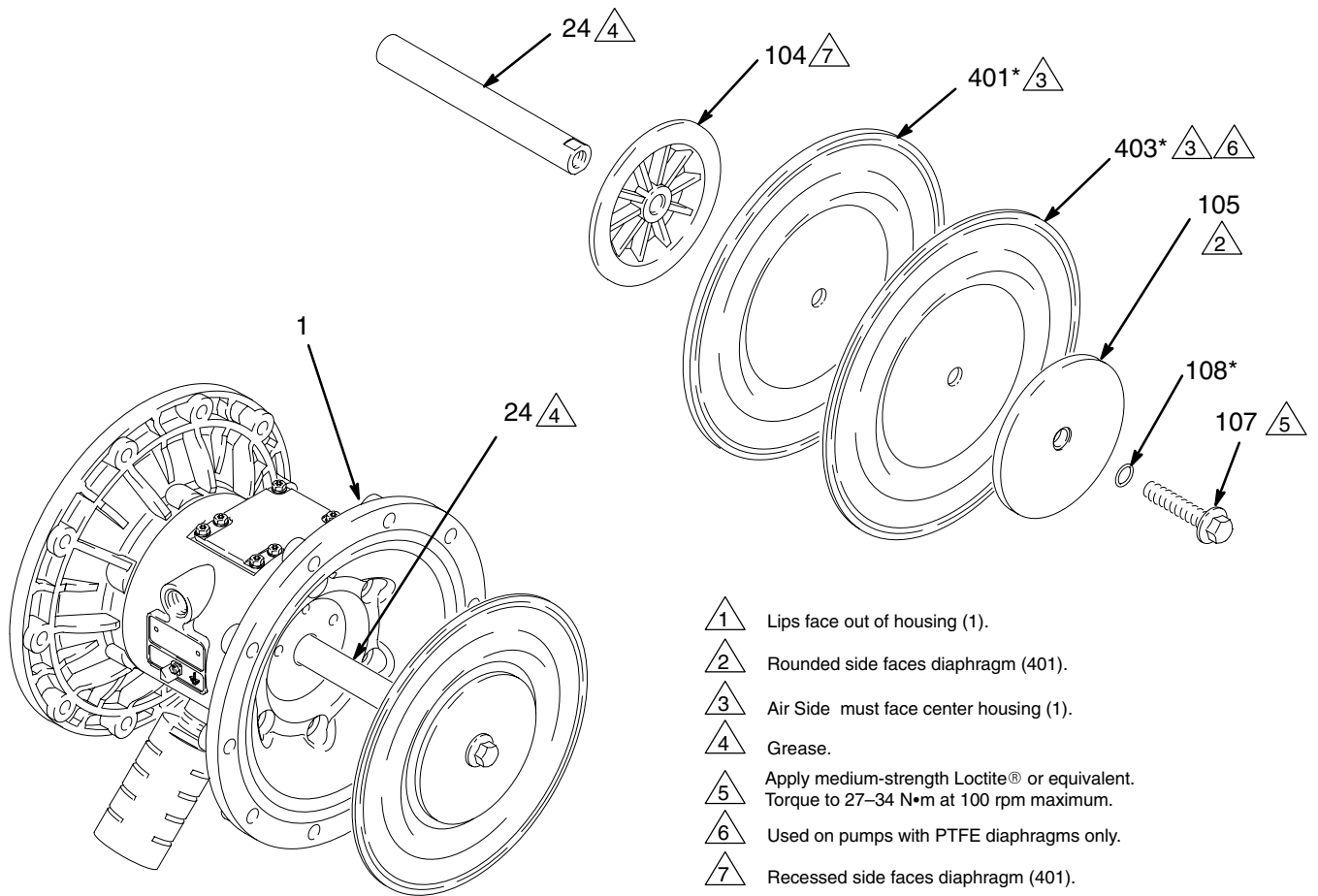

- 1 Lips face out of housing (1).
- 2 Rounded side faces diaphragm (401).
- 3 Air Side must face center housing (1).
- 4 Grease.
- 5 Apply medium-strength Loctite® or equivalent. Torque to 27–34 N•m at 100 rpm maximum.
- 6 Used on pumps with PTFE diaphragms only.
- 7 Recessed side faces diaphragm (401).

Fig. 12

03276B

Service

Bearing and Air Gasket Removal

Tools Required

- Torque wrench
- 10 mm socket wrench
- Bearing puller
- O-ring pick
- Press, or block and mallet

Disassembly

NOTE: Do not remove undamaged bearings.

Warning

To reduce the risk of serious injury whenever you are instructed to relieve pressure, always follow the **Pressure Relief Procedure** on page 9.

1. Relieve the pressure.
2. Remove the manifolds and disassemble the ball check valves as explained on page 16.
3. Remove the fluid covers and diaphragm assemblies as explained on page 17.

NOTE: If you are removing only the diaphragm shaft bearing (19), skip step 4.



4. Disassemble the air valve as explained on page 14.
5. Using a 10 mm socket wrench, remove the screws (25) holding the air covers (23) to the center housing (1). See Fig. 13.
6. Remove the air cover gaskets (22). Always replace the gaskets with new ones.
7. Use a bearing puller to remove the diaphragm shaft bearings (19), air valve bearings (12) or pilot pin bearings (15). Do not remove undamaged bearings.
8. If you removed the diaphragm shaft bearings (19), reach into the center housing (1) with an o-ring pick and hook the u-cup packings (402), then pull them out of the housing. Inspect the packings. See Fig. 12.

Reassembly

1. If removed, install the shaft u-cup packings (402*) so the lips face **out** of the housing (1).

2. The bearings (12, 15, and 19) are tapered and can only be installed one way. Insert the bearings into the center housing (1), **tapered end first**. Using a press or a block and rubber mallet, press-fit the bearing so it is flush with the surface of the center housing.
3. Reassemble the air valve as explained on page 15.
4. Align the new air cover gasket (22) so the pilot pin (16) protruding from the center housing (1) fits through the proper hole (H) in the gasket.
5. Align the air cover (23) so the pilot pin (16) fits in the middle hole (M) of the three small holes near the center of the cover. Install the screws (25), handtight. See Fig. 13. Using a 10 mm socket wrench, torque the screws oppositely and evenly to 15–17 N•m.
6. Install the diaphragm assemblies and fluid covers as explained on page 17.
7. Reassemble the ball check valves and manifolds as explained on page 16.

Service

- 1  Insert bearings tapered end first.
- 2  Press-fit bearings flush with surface of center housing (1).
- 3  Torque to 15–17 N•m.

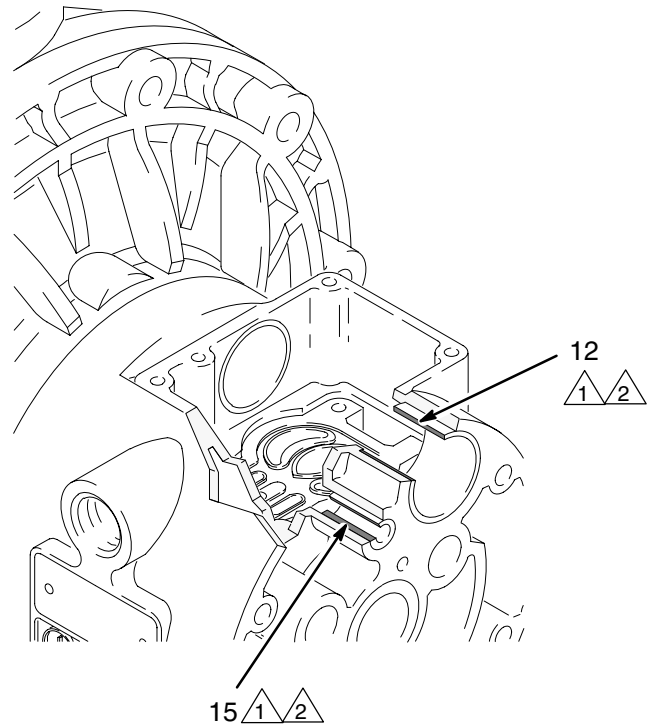

Detail of Air Valve Bearings

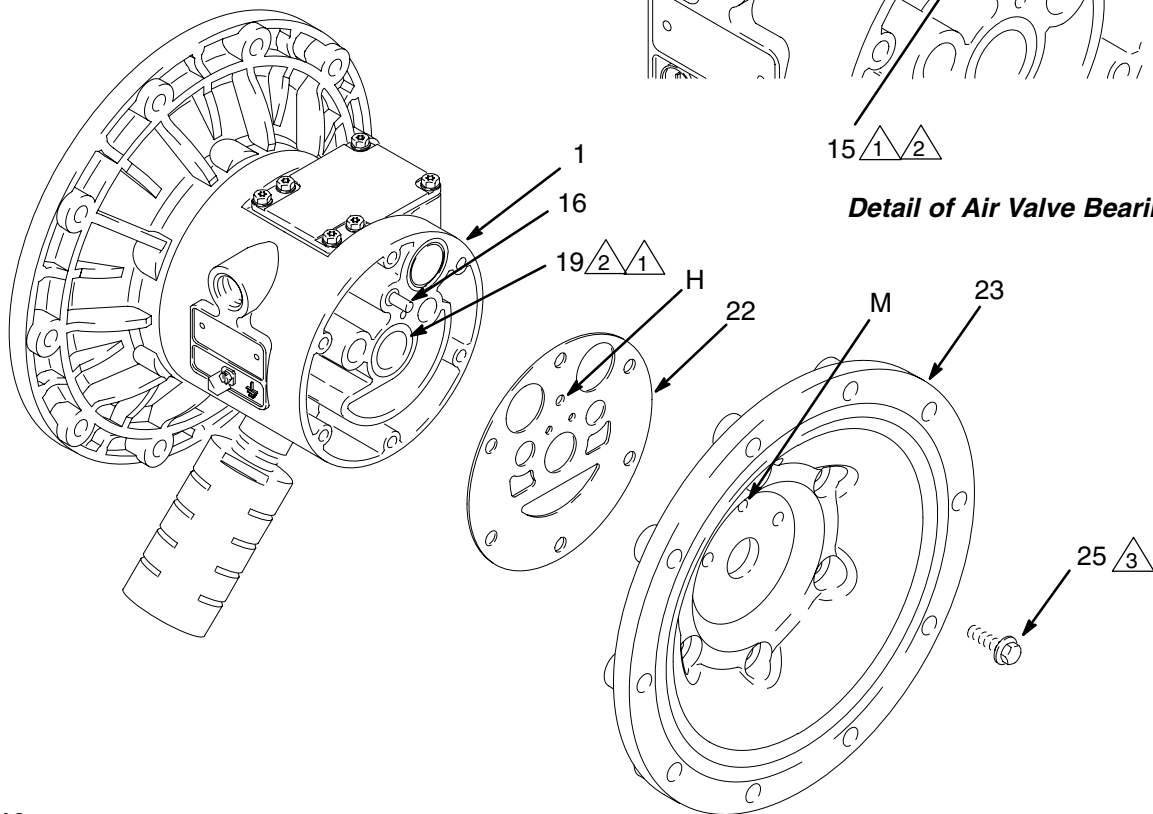

03277

03278B

Fig. 13

Pump Listing

VERDERAIR VA 40 Aluminium and Stainless Steel pumps, Series B

Your Model No. is marked on the pump's serial plate. The listing of existing **VERDERAIR VA 40** pumps is below:

Part No.	Air Section	Fluid Section	Seats	Balls	Diaphragms
810.1632	ALU	ALU	316	TEF	TEF
810.1633	ALU	ALU	316	TEF	HYT
810.1640	ALU	ALU	316	440	TEF
810.1685	ALU	ALU	HYT	ACE	HYT
810.1722	ALU	ALU	SAN	SAN	SAN
810.1752	ALU	ALU	POL	TEF	TEF
810.1770	ALU	ALU	POL	SAN	SAN
810.6986	ALU	ALU	GEO	GEO	GEO
810.6987	ALU	SST	316	GEO	GEO
810.1800	ALU	SST	316	TEF	TEF
810.1818	ALU	SST	316	SAN	SAN
810.1823	ALU	SST	316	VIT	VIT
810.1853	ALU	SST	HYT	ACE	HYT
810.1857	ALU	SST	HYT	440	HYT
810.1890	ALU	SST	SAN	SAN	SAN
810.1920	ALU	SST	POL	TEF	TEF
810.7026	ALU	SST	SST	TEF	TEF
810.0092	ALU	ALU	SST	BUN	BUN
810.0093	ALU	ALU	BUN	BUN	BUN
810.0094	ALU	ALU	VIT	VIT	VIT
810.0095	ALU	SST	SST	BUN	BUN
810.0096	ALU	SST	VIT	VIT	VIT
810.0195	ALU	ALU	SST	TEF	TEF
810.0196	ALU	ALU	GEO	GEO	GEO
810.0197	ALU	ALU	SAN	SAN	SAN
810.0198	ALU	SST	SST	TEF	TEF
810.0101	SST	SST	SST	BUN	BUN
810.0102	SST	SST	SST	TEF	TEF
810.0103	SST	SST	VIT	VIT	VIT
810.0783	ALU	ALU	SST	TEF	PO
810.0483	ALU	SST	316	SAN	SAN
810.0484	ALU	SST	316	BUN	BUN
810.0485	ALU	SST	316	GEO	GEO
810.0486	ALU	SST	GEO	GEO	GEO

ACE = Acetal HYT = TPE POL = Polypropylene 316 = 316 sst TEF = PTFE ALU= Aluminium SAN = Santoprene
VIT = Fluoroelastomer SST = 316 Stainless Steel GEO = Geolast PO = PTFE/EPDM Overmolded BUN = Buna-N

819.7138, Stainless Steel Air Motor Conversion Kit

Use kit 819.7138 and refer to instruction manual 819.7140 (included with kit) to convert from aluminum air motor to stainless steel air motor.

Repair Kit Listing

VERDERAIR VA 40 Aluminium and Stainless Steel Pumps, Series B

Repair Kits may only be ordered as kits. To repair the air valve, order **Part No. 819.4274** for aluminum center housing models and **Part No. 819.0249** for stainless steel center housing models (see page 24). Parts included in the Air Valve Repair Kit are marked with a symbol in the parts list, for example (4†■). The list of existing Repair Kits is below:

Part No.	O-Rings	Seats	Balls	Diaphragms
819.1966	TEF	316	BUN	BUN
819.1969	TEF	NUL	NUL	TEF
819.1970	TEF	NUL	NUL	HYT
819.1971	TEF	NUL	NUL	SAN
819.1972	TEF	NUL	NUL	VIT
819.2008	TEF	316	TEF	NUL
819.2009	TEF	316	TEF	TEF
819.2010	TEF	316	TEF	HYT
819.2019	TEF	316	440	TEF
819.2028	TEF	316	SAN	NUL
819.2031	TEF	316	SAN	SAN
819.2033	TEF	316	VIT	NUL
819.2037	TEF	316	VIT	VIT
819.2084	TEF	HYT	ACE	TEF
819.2085	TEF	HYT	ACE	HYT
819.2090	TEF	HYT	440	HYT
819.2133	TEF	SAN	SAN	NUL
819.2136	TEF	SAN	SAN	SAN
819.2177	TEF	VIT	VIT	VIT
819.2083	TEF	HYT	ACE	NUL
819.2184	TEF	POL	TEF	TEF
819.2192	TEF	POL	ACE	VIT
819.2206	TEF	POL	SAN	SAN
819.3802	TEF	GEO	GEO	GEO
819.3801	TEF	316	GEO	GEO
819.0305	-	-	-	PO

For 810.0783 diaphragm repair kit, order PN 819.0305.

ACE = Acetal HYT = TPE POL = Polypropylene 316 = 316 sst TEF = PTFE ALU= Aluminium SAN = Santoprene
 VIT = Fluoroelastomer SST = Stainless Steel NUL = Null 440 = 440C sst GEO = Geolast PO = PTFE/EPDM Overmolded
 BUN = Buna-N

Parts

Air Motor Parts List

Ref. No.	Part No.	Description	Qty
1	819.4275	HOUSING, center; alum.	1
	819.0247	HOUSING, center; stainless steel	1
2	819.4276	COVER, air valve; alum.	1
	819.0259	COVER, air valve; stainless steel	1
3	819.0221	SCREW, mach, hex flange hd; M5 x 0.8; 12 mm	9
4†■	819.4278	GASKET, cover; Santoprene®	1
5	819.4279	CARRIAGE; aluminum	1
6†■	819.4280	O-RING; nitrile	1
7†■	819.4281	BLOCK, air valve; acetal	1
8■	Aluminum 819.4282	PLATE, air valve; stainless steel	1
	SST 819.0248	PLATE, air valve; stainless steel	1
9†	Aluminum 819.4283	SEAL, valve plate; buna-N	1
	SST -	-	-
10†■	819.4284	PACKING, u-cup; nitrile	2
11	819.4285	PISTON, actuator; acetal	2
12	819.4286	BEARING, piston; acetal	2
15	819.4287	BEARING, pin; acetal	2
16	819.4288	PIN, pilot; stainless steel	2
17†■	819.4289	O-RING; buna-N	2
18†■	819.4290	BLOCK, pilot; acetal	1
19	819.4291	BEARING, shaft; acetal	2
20	819.0220	SCREW, grounding	1
22	819.4294	GASKET, air cover; foam	2
	819.7107	COVER, air; stainless steel	2
23	819.4336	COVER, air; aluminum	2
24	819.4337	SHAFT, diaphragm; sst	1
25	819.7051	SCREW; M8 x 1.25; 25 mm aluminum	12
	819.4297	SCREW; M8 x 1.25; 25 mm, stainless steel	12

Fluid Section Parts List

Fluid Section Material	Ref. No.	Part No.	Description	Qty	
A L U M I N I U M	101	819.0226	COVER, fluid; aluminum	2	
	102	819.6980	MANIFOLD, inlet; aluminum	1	
		819.4339	MANIFOLD, inlet; aluminum, npt (for 810.0195, 810.0196, and 810.0197 only)	1	
	103	819.0228	MANIFOLD, outlet; aluminum	1	
		819.0227	MANIFOLD, outlet; aluminum, npt (for 810.0195, 810.0196, and 810.0197 only)	1	
	104	819.0258	PLATE, air side; aluminum	2	
	105	819.4342	PLATE, fluid side; carbon steel	2	
	106	819.7052	SCREW; M10 x 1.18; 30 mm, sst	24	
	107	819.4312	BOLT; M12 x 1.75; 55 mm; sst	2	
	108*	819.4304	O-RING; PTFE	2	
	110▲	819.6310	LABEL, warning	1	
	111	819.7000	MUFFLER	1	
	112	819.7053	SCREW; M10 x 1.50; 90 mm	4	
	S T A I N L E S S	101	819.7076	COVER, fluid; sst	2
		102	819.9749	MANIFOLD, inlet; sst	1
			819.7049	MANIFOLD, inlet, aluminum, npt, for 810.0198 only	1
103		819.9750	MANIFOLD, outlet; sst	1	
		819.7048	MANIFOLD, outlet; aluminum, npt (for 810.0198 only)	1	
104		819.0258	PLATE, air side; aluminum	2	
105		819.4348	PLATE, fluid side; sst	2	
106		819.4343	SCREW; M10 x 1.18; 30 mm; sst	24	
107		819.4312	BOLT; M12 x 1.75; 55 mm; sst	2	
108*		819.4304	O-RING; PTFE	2	
110▲		819.6314	LABEL, warning	1	
111		819.7000	MUFFLER	1	
112	819.4307	SCREW; M10 x 1.50; 90 mm; sst	4		
S T E E L	101	819.7076	COVER, fluid; sst	2	
	102	819.9749	MANIFOLD, inlet; sst	1	
		819.7049	MANIFOLD, inlet, aluminum, npt, for 810.0198 only	1	
	103	819.9750	MANIFOLD, outlet; sst	1	
		819.7048	MANIFOLD, outlet; aluminum, npt (for 810.0198 only)	1	
	104	819.0258	PLATE, air side; aluminum	2	
	105	819.4348	PLATE, fluid side; sst	2	
	106	819.4343	SCREW; M10 x 1.18; 30 mm; sst	24	
	107	819.4312	BOLT; M12 x 1.75; 55 mm; sst	2	
	108*	819.4304	O-RING; PTFE	2	
	110▲	819.6314	LABEL, warning	1	
	111	819.7000	MUFFLER	1	
112	819.4307	SCREW; M10 x 1.50; 90 mm; sst	4		

Parts Drawing

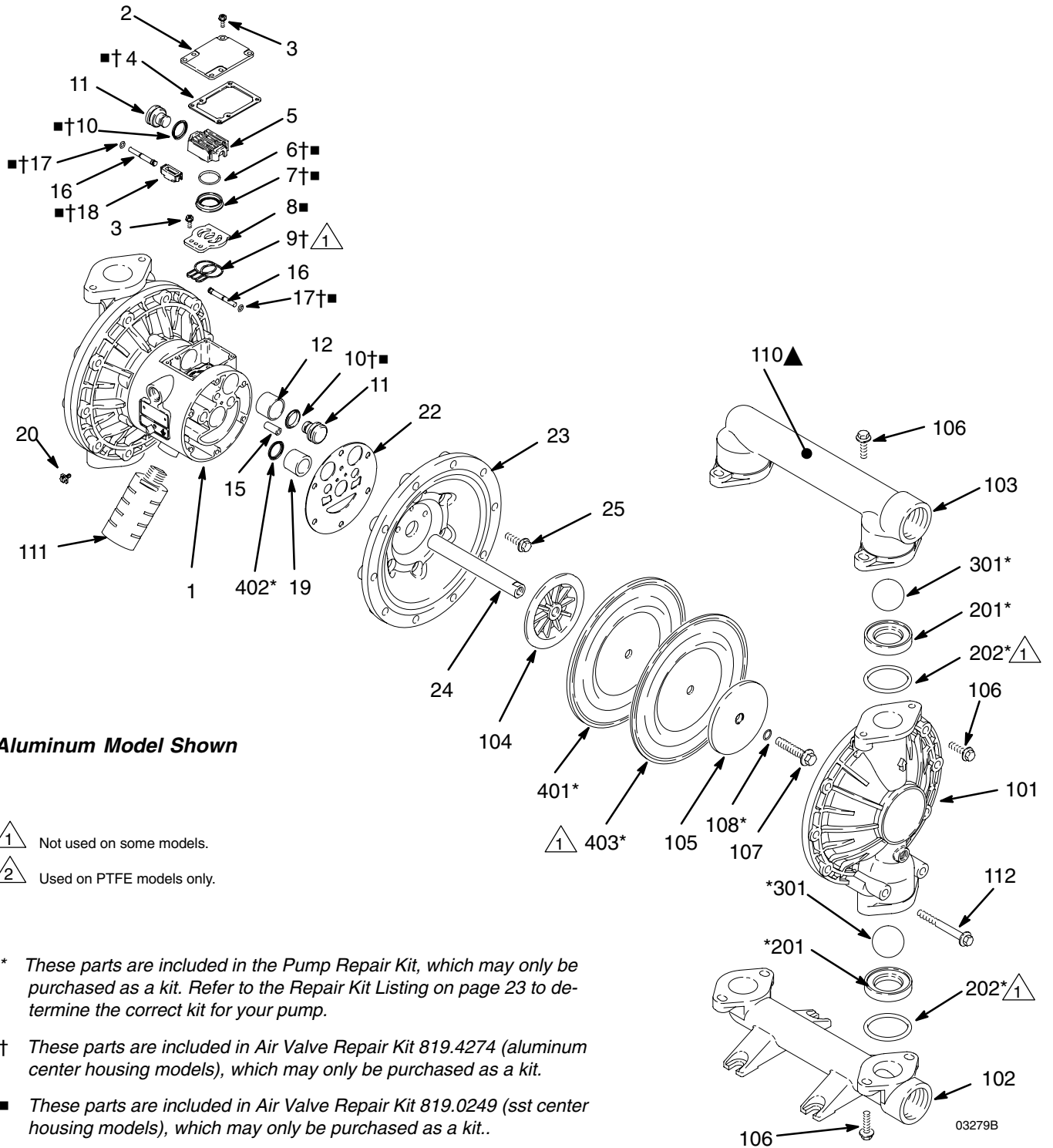

Aluminum Model Shown

△1 Not used on some models.

△2 Used on PTFE models only.

* These parts are included in the Pump Repair Kit, which may only be purchased as a kit. Refer to the Repair Kit Listing on page 23 to determine the correct kit for your pump.

† These parts are included in Air Valve Repair Kit 819.4274 (aluminum center housing models), which may only be purchased as a kit.

■ These parts are included in Air Valve Repair Kit 819.0249 (sst center housing models), which may only be purchased as a kit..

▲ Replacement Danger and Warning labels, tags and cards are available at no cost.

Parts

Seat Parts List

Seat Material	Ref. No.	Part No.	Description	Qty
3 1 6 S S T	201*	819.4349	SEAT; 316 stainless steel	4
	202*	819.4350	O-RING; PTFE	4
1 7 - 4 S S T	201*	819.4351	SEAT; 17-4 stainless steel	4
	202*	819.4350	O-RING; PTFE	4
T P E	201*	819.4352	SEAT; TPE	4
	202	None	Not Used	0
S A N T O P R E N E	201*	819.4353	SEAT; Santoprene	4
	202*	819.4350	O-RING; PTFE	4
B U N A - N	201*	819.7116	SEAT; Buna-N	4
	202*	NONE	NOT USED	0
FLUOR OELAS TOMER	201*	819.7114	SEAT; fluoroelastomer	4
	202	None	Not Used	0

P O L Y P R O P Y L E N E	201*	819.4355	SEAT; polypropylene	4
	202*	819.4350	O-RING; PTFE	4
P V D F	201*	819.4356	SEAT; PVDF	4
	202*	819.4350	O-RING; PTFE	4
G E O L A S T	201*	819.7060	SEAT; Geolast	4
	202*	819.4350	O-RING; PTFE	4

Ball Parts List

Ref. No.	Part No.	Description	Qty
301*	819.4357	BALL; PTFE	4
301*	819.4358	BALL; acetal	4
301*	819.4359	BALL; 440C stainless steel	4
301*	819.4360	BALL; TPE	4
301*	819.4361	BALL; Santoprene	4
301*	819.7127	BALL; Buna-N	4
301*	819.7126	BALL; Fluoroelastomer	4
301*	819.7059	BALL; Geolast	4

Parts

Diaphragm Parts List

Diaphragm Material	Ref. No.	Part No.	Description	Qty
PTFE	401*	not sold separately	DIAPHRAGM, backup; polychloroprene (CR)	2
	402*	819.4284	PACKING, u-cup; nitrile	2
PTFE / EPDM	401*	not sold separately	DIAPHRAGM, Overmolded	2
	402*	819.4284	PACKING, u-cup; nitrile	2
PTFE	403*	819.0270	DIAPHRAGM; PTFE	2
TPE	401*	819.4363	DIAPHRAGM; TPE	2
	402*	819.4284	PACKING, u-cup; nitrile	2
SANTOPRENE	401*	819.4365	DIAPHRAGM; Santoprene	2
	402*	819.4284	PACKING, u-cup; nitrile	2
BUNA-N	401*	819.7119	DIAPHRAGM; Buna-N	2
	402*	819.4284	PACKING, u-cup; Buna-N	2
FLUOROELASTOMER	401*	819.7132	DIAPHRAGM; Fluoroelastomer	2
	402*	819.4284	PACKING, u-cup; nitrile	2
GEOLAST	401*	819.7061	DIAPHRAGM; Geolast	2
	402*	819.4284	PACKING; u-cup; nitrile	2

* These parts are included in the pump repair kit, purchased separately. See Repair Kit Listing on page 23 to determine the correct kit for your pump.

Torque Sequence

Always follow torque sequence when instructed to torque fasteners.

1. Left/Right Fluid Covers
Torque bolts to 22–25 N•m.

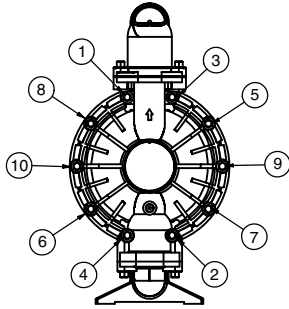

SIDE VIEW

2. Inlet Manifold
Torque bolts to 14–17 N•m.

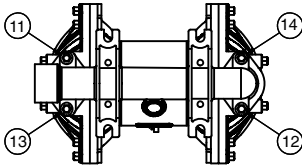

BOTTOM VIEW

3. Outlet Manifold
Torque bolts to 14–17 N•m.

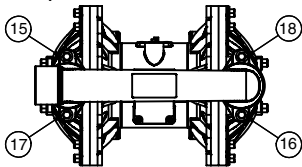

TOP VIEW

Dimensions

FRONT VIEW

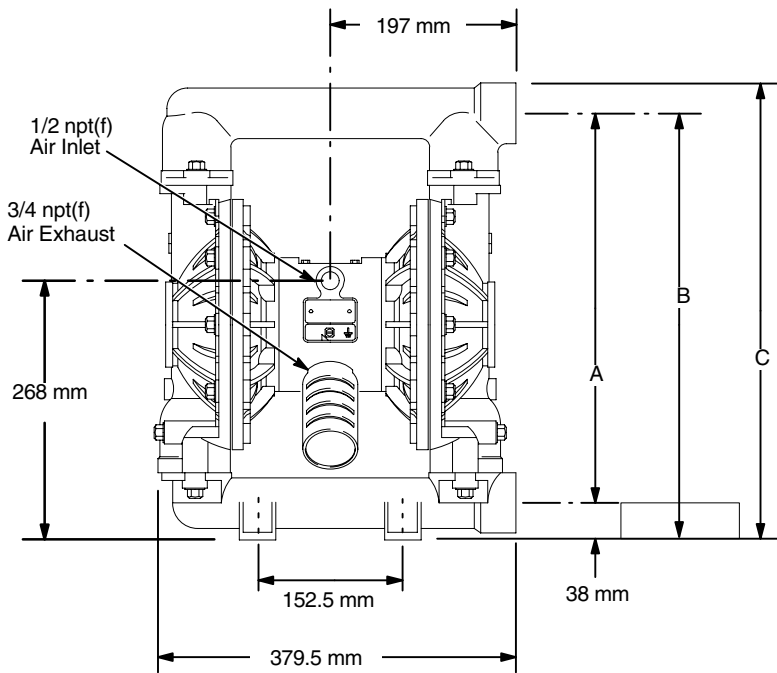

SIDE VIEW

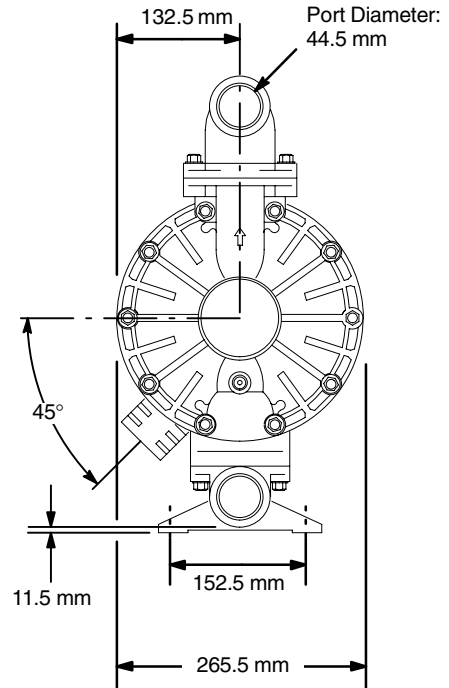

7438B

PUMP MOUNTING HOLE PATTERN

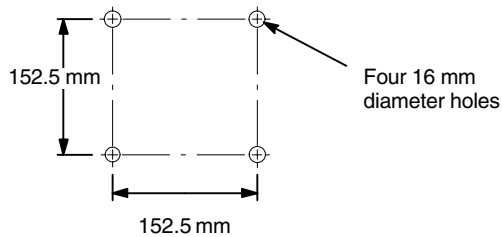

Dimension	Aluminum Pump	Stainless Steel Pump
A	427 mm	412.5 mm
B	465 mm	451 mm
C	497 mm	482.5 mm

Technical Data

Maximum Fluid Working Pressure 8.4 bar
 Air Pressure Operating Range 1.4–8.4 bar
 Maximum Air Consumption 4.9 N m³/min
 Air Consumption at 4.9 bar/
 227 l/min 1.68 N m³/min (see chart)
 Maximum Free Flow Delivery 378.5 l/min
 Maximum Pump Speed 200 cpm
 Liters per cycle 1.9
 Maximum Suction Lift 5.48 m wet or dry
 Maximum Size Pumpable Solids 4.8 mm
 * Sound Pressure Level at 7 bar, full flow 94 dBa
 * Sound Power Level at 7 bar, full flow 108 dBa
 * Sound Pressure Level at 4.9 bar, 50 cycles/min ... 72 dBa
 Maximum Operating Temperature 65.5°C;
 93.3°C for models with PTFE diaphragms
 Air Inlet Size 1/2 npt(f)

†Fluid Inlet Size 1–1/2 in. bspt
 †Fluid Outlet Size 1–1/2 in. bspt
 Wetted Parts Vary by Model. Refer to pages 22–25.
 Non-wetted External Parts ... Aluminum, 302, 316 Stainless
 Steel, Polyester (labels)
 Weight *Aluminum Pumps:* 15.2 kg
 *Stainless Steel Pumps with aluminum air motors:* 32.7 kg
 . *Stainless Steel Pumps with stainless steel air motors:* 40 kg

Santoprene® is a registered trademark of the Monsanto Co.

* Sound pressure levels measured with the pump mounted on the floor, using Rubber Foot Kit 819.4333. Sound power measured per ISO Standard 9614–2.

† Inlet and outlet size is 1–1/2 in. npt for 810.0195, 810.0196, 810.0197, and 810.0198.

Example of Finding Pump Air Consumption and Air Pressure at a Specific Fluid Delivery and Discharge Head:

To supply 227 liters fluid flow (horizontal scale) at 2.8 bar discharge head pressure (vertical scale) requires approximately 1.40 N m³/min air consumption at 4.9 bar inlet air pressure.

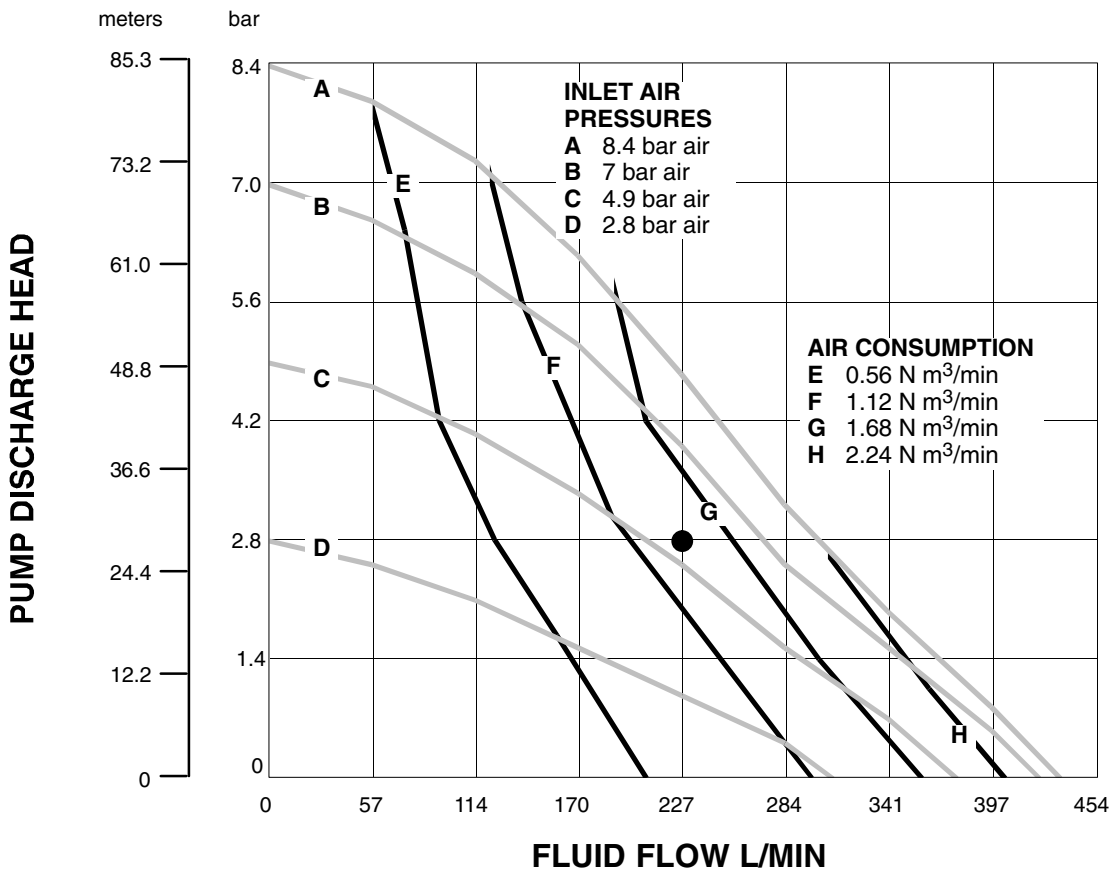

TEST CONDITIONS

Pump tested in water with PTFE diaphragm and inlet submerged.

KEY ——— FLUID PRESSURE AND FLOW
 ——— N M³/MIN AIR CONSUMPTION

Notes

Customer Services/Guarantee

CUSTOMER SERVICES

If you require spare parts, please contact your local distributor, providing the following details:

- Pump Model
- Type
- Serial Number, and
- Date of First Order.

GUARANTEE

All VERDER pumps are warranted to the original user against defects in workmanship or materials under normal use (rental use excluded) for two years after purchase date. This warranty does not cover failure of parts or components due to normal wear, damage or failure which in the judgement of VERDER arises from misuse.

Parts determined by VERDER to be defective in material or workmanship will be repaired or replaced.

LIMITATION OF LIABILITY

To the extent allowable under applicable law, VERDER's liability for consequential damages is expressly disclaimed. VERDER's liability in all events is limited and shall not exceed the purchase price.

WARRANTY DISCLAIMER

VERDER has made an effort to illustrate and describe the products in the enclosed brochure accurately; however, such illustrations and descriptions are for the sole purpose of identification and do not express or imply a warranty that the products are merchantable, or fit for a particular purpose, or that the products will necessarily conform to the illustration or descriptions.

PRODUCT SUITABILITY

Many regions, states and localities have codes and regulations governing the sale, construction, installation and/or use of products for certain purposes, which may vary from those in neighbouring areas. While VERDER attempts to assure that its products comply with such codes, it cannot guarantee compliance, and cannot be responsible for how the product is installed or used. Before purchasing and using a product, please review the product application as well as the national and local codes and regulations, and be sure that product, installation, and use complies with them.

VERDER

EC-DECLARATION OF CONFORMITY

EG-VERKLARING VAN OVEREENSTEMMING, DÉCLARATION DE CONFORMITÉ CE, EG-KONFORMITÄTSEKTLÄRUNG, DICHIARAZIONE DI CONFORMITÀ CE, EF-OVERENSSTEMMELSESEKTLÆRING, ΕΚ-ΔΗΛΩΣΗ ΣΥΜΜΟΡΦΩΣΗΣ, DECLARAÇÃO DE CONFORMIDADE - CE, DECLARACIÓN DE CONFORMIDAD DE LA CE, EY-VAATIMUSTENMUKAISUUSVAKUUTUS, EG-DEKLARATION OM ÖVERENSSTÄMMELSE, ES PROHLÁŠENÍ O SHODĚ, EÜ VASTAVUSDEKLARATSIOON, EC MEGFEIÉLŐSÉGI NYILATKOZAT, EK ATBILSTÍBAS DEKLARACIJA, ES ATITIKTIES DEKLARACIJA, DEKLARACJA ZGODNOŚCI UE, DIKJARAZZJONI-KE TA' KONFORMITA', IZJAVA ES O SKLADNOSTI, ES - VYHLÁSENIE O ZHODE, EO-ΔΕΚΛΑΡΑЦИЯ ЗА СЪВМЕСТИМОСТ, DEIMHNIÚ COMHREIREACHTA CE, CE-DECLARAȚIE DE CONFORMITATE

Model

VERDERAIR VA 40

Modèle, Modell, Modello, Μοντέλο,
Modelo, Malli, Mudel, Modelis, Mudell, Модел, Samhail

Part

Bestelnr., Type, Teil, Codice, Del, Μέρος, Peça,
Referencia, Osa, Součást, Részegység, Daja,
Dalis, Część, Taqsim, Čast, Част, Páirt, Parte

810.0092–810.0096, 810.0101–810.0103, 810.0195–810.0198,
810.0483–810.0486, 810.0783, 810.1632–810.1750, 810.1752–810.1967,
810.6985–810.6988, 810.7006, 810.7022–810.7026

Complies With The EC Directives:

Voldoet aan de EG-richtlijnen, Conforme aux directives CE, Entspricht den EG-Richtlinien, Conforme alle direttive CE, Overholder EF-direktiverne, Σύμφωνα με τις Οδηγίες της ΕΚ, Em conformidade com as Directivas CE, Cumple las directivas de la CE, Täyttää EY-direktiivien vaatimukset, Oppfyller EG-direktiven, Shoda se směrnicemi ES, Vastab EÜ direktiividele, Kielégíti az EK irányelvek követelményeit, Atbilst EK direktīvām, Atitinka šias ES direktyvas, Zgodność z Dyrektywami UE, Konformi mad-Direttivi tal-KE, V skladu z direktivami ES, Je v súlade so smernicami ES, Съвместимост с Директиви на ЕО, Tá ag teacht le Treoracha an CE, Respectă directivele CE

2006/42/EC Machinery Directive94/9/EC ATEX Directive (EX II 2 GD c IIC T4) – Tech File stored with NB 0359

Standards Used:

Gebruikte maatstaven, Normes respectées, Verwendete Normen, Norme applicate, Anvendte standarder, Πρότυπα που χρησιμοποιήθηκαν, Normas utilizadas, Normas aplicadas, Sovellettavat standardit, Tillämpade standarder, Použité normy, Rakendatud standardid, Alkalmazott szabványok, Izmantotie standarti, Taikyti standartai, Užyte normy, Standards Užati, Uporabljeni standardi, Použité normy, Използвани стандарти, Cíghdeáin arna n-úsáid, Standarde utilizate

EN 1127-1EN 13463-1ISO 12100ISO 9614-1

Notified Body for Directive

Aangemelde instantie voor richtlijn, Organisme notifié pour la directive, Benannte Stelle für diese Richtlinie, Ente certificatore della direttiva, Bemyndiget organ for direktiv, Διακοινωμένο όργανο Οδηγίας, Organismo notificado relativamente à directiva, Organismo notificado de la directiva, Direktiivin mukaisesti ilmoitettu tarkastuslaitos, Anmält organ för direktivet, Úředně oznámený orgán pro směrnici, Teavitatud asutus (direktiivi järgi), Az irányelvekkel kapcsolatlan értesített testület, Piilvarotā iestāde saskaņā ar direktīvu, Apie direktīvą Informuota institucija, Ciało powiadomione dla Dyrektywy, Korp avzat bid-Direttiva, Priglašeni organ za direktivo, Notifikovaný orgán pre smernicu, Нотифициран орган за Директива, Comhlacht ar tugadh fógra dó, Organism notificat în conformitate cu directiva

Approved By:

Goedgekeurd door, Approuvé par, Genehmigt von, Approvato da, Godkendt af, Έγκριση από, Aprobado por, Aprobado por, Hyväksynyt, Intygas av, Schwáilil, Kinnitanud, Jóváhagyta, Apstiprināts, Patvirtino, Zatwierdzone przez, Approvat minn, Odobril, Schwálené, Одобрено от, Faofa ag, Aprobat de



Frank Meersman
Director

1 April 2013

VERDER NV
Kontichsesteenweg 17
B-2630 Aartselaar
BELGIUM

819.5960

Austria

Verder Austria
Eitnergasse 21/Top 8
A-1230 Wien
AUSTRIA
Tel: +43 1 86 51 074 0
Fax: +43 1 86 51 076
e-mail: office@verder.at

Belgium

Verder nv
Kontichsesteenweg 17
B-2630 Aartselaar
BELGIUM
Tel: +32 3 877 11 12
Fax: +32 3 877 05 75
e-mail: info@verder.be

China

Verder Retsch Shanghai Trading
Room 301, Tower 1
Fuhai Commercial Garden no 289
Bisheng Road, Zhangjiang
Shanghai 201204
CHINA
Tel: +86 (0)21 33 93 29 50 / 33 93 29 51
Fax: +86 (0)21 33 93 29 55
e-mail: info@verder.cn

Czech Republic

Verder s.r.o.
Vodnanská 651/6 (vchod Chlu-
mecka 15)
198 00 Praha 9-Kyje
CZECH REPUBLIC
Tel: +420 261 225 386-7
Web: <http://www.verder.cz>
e-mail: info@verder.cz

Denmark

Verder A/S
H.J. Holstvej 26
DK 2610 Rodovre
DENMARK
Tel: +45 3636 4600
e-mail: info@verder.dk

France

Verder France
Parc des Bellevues
Rue du Gros Chêne
F-95610 Eragny sur Oise
FRANCE
Tel: +33 134 64 31 11
Fax: +33 134 64 44 50
e-mail: verder-info@verder.fr

Germany

Verder Deutschland GmbH
Retsch-Allee 1-5
42781 Haan
GERMANY
Tel: 02104/2333-200
Fax: 02104/2333-299
e-mail: info@verder.de

Hungary

Verder Hungary Kft
Budafoke ut 187 – 189
HU-1117 Budapest
HUNGARY
Tel: 0036 1 3651140
Fax: 0036 1 3725232
e-mail: info@verder.hu

The Netherlands

Verder BV
Leningradweg 5
NL 9723 TP Groningen
THE NETHERLANDS
Tel: +31 50 549 59 00
Fax: +31 50 549 59 01
e-mail: info@verder.nl

Poland

Verder Polska
ul.Ligonia 8/1
PL-40 036 Katowice
POLAND
Tel: +48 32 78 15 032
Fax: +48 32 78 15 034
e-mail: verder@verder.pl

Romania

Verder România
Drumul Balta Doamnei no
57-61
Sector 3
CP 72-117
032624 Bucuresti
ROMANIA
Tel: +40 21 335 45 92
Fax: +40 21 337 33 92
e-mail: office@verder.ro

Slovak Republic

Verder Slovakia s.r.o.
Silacska 1
SK-831 02 Bratislava
SLOVAK REPUBLIC
Tel: +421 2 4463 07 88
Fax: +421 2 4445 65 78
e-mail: info@verder.sk

South Africa

Verder SA
197 Flaming Rock Avenue
Northlands Business Park
Newmarket Street
ZA Northriding
SOUTH AFRICA
Tel: +27 11 704 7500
Fax: +27 11 704 7515
e-mail: info@verder.co.za

Switzerland

Verder AG
Auf dem Wolf 19
CH-4052 Basel
SWITZERLAND
Tel: +41 (0)61 373 7373
e-mail: info@verder.ch

United Kingdom

Verder Ltd.
Whitehouse Street
GB-Hunslet, Leeds LS10 1AD
UNITED KINGDOM
Tel: +44 113 222 0250
Fax: +44 113 246 5649
e-mail: info@verder.co.uk

United States of America

Verder Inc.
110 Gateway Drive
Macon, GA 31210
USA
Toll Free: 1 877 7 VERDER
Tel: +1 478 471 7327
Fax: +1 478 476 9867
e-mail: info@verder.com